

Unit 5: Placement

- Course contents:
 - Placement metrics
 - Constructive placement: cluster growth, min cut
 - Iterative placement: force-directed method, simulated annealing, genetic algorithm

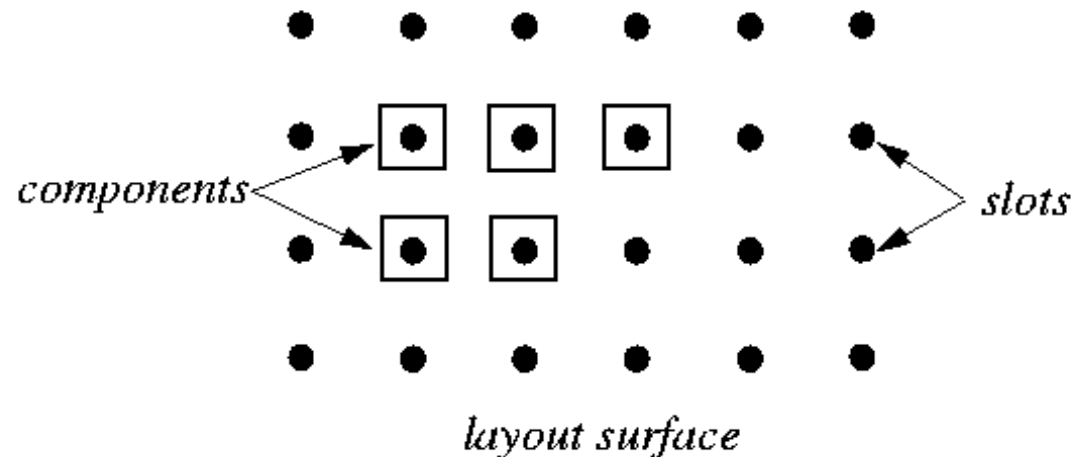

Placement

- **Placement** is the problem of automatically assigning correct positions on the chip to predesigned cells, such that some cost function is optimized.
- Inputs: A set of **fixed** cells/modules, a netlist.
- Goal: Find the best position for each cell/module on the chip according to appropriate cost functions.
 - Considerations: **routability/channel density**, **wirelength**, cut size, performance, thermal issues, I/O pads.

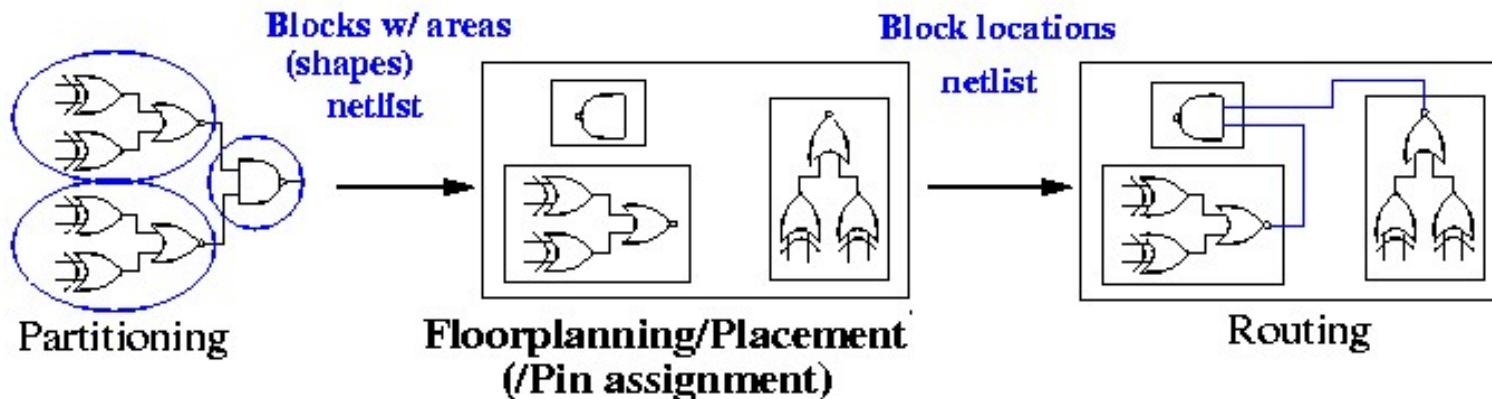

Placement Objectives and Constraints

- What does a placement algorithm try to optimize?
 - the total area
 - the total wire length
 - the number of horizontal/vertical wire segments crossing a line
- Constraints:
 - the placement should be routable (no cell overlaps; no density overflow).
 - timing constraints are met (some wires should always be shorter than a given length).

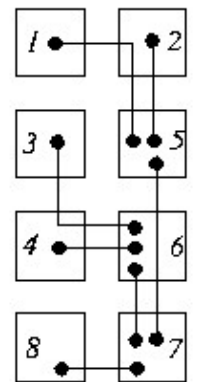
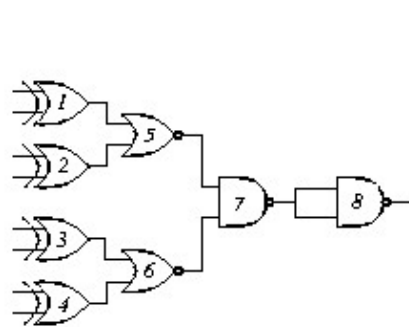

wirelength = 10

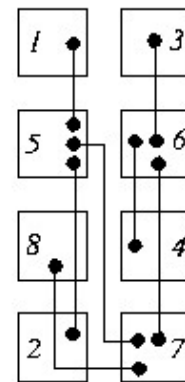

wirelength = 12

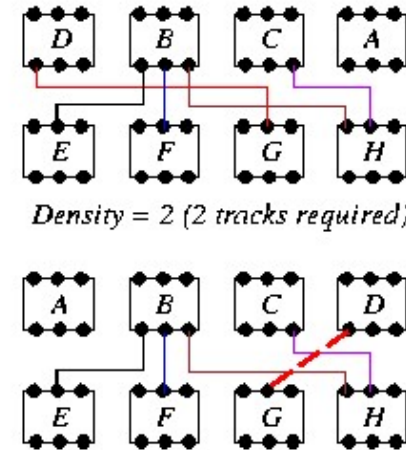

Density = 2 (2 tracks required)

Shorter wirelength, 3 tracks required.

VLSI Placement: Building Blocks

- Different design styles create different placement problems.
 - E.g., building-block, standard-cell, gate-array placement
- Building block: The cells to be placed have arbitrary shapes.

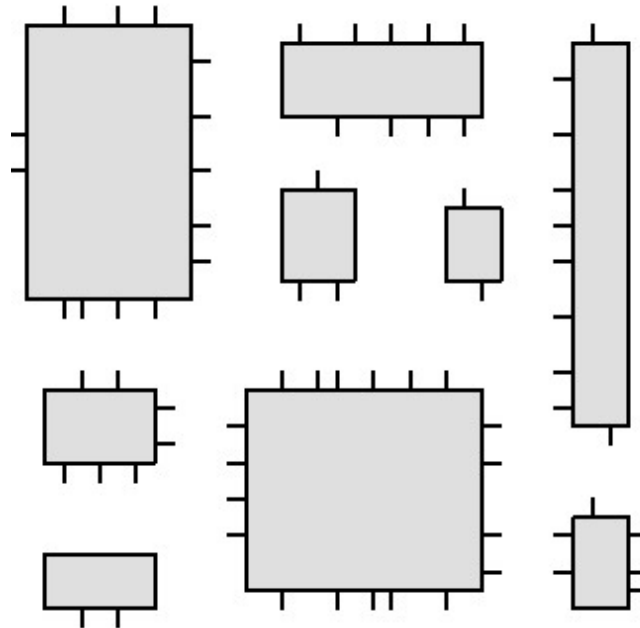

Building block

Consequences of Fabrication Method

- Full-custom fabrication (building block):
 - Free selection of aspect ratio (quotient of height and width).
 - Height of wiring channels can be adapted to necessity.
- Semi-custom fabrication (gate array, standard cell):
 - Placement has to deal with fixed carrier dimensions.
 - Placement should be able to deal with fixed channel capacities.

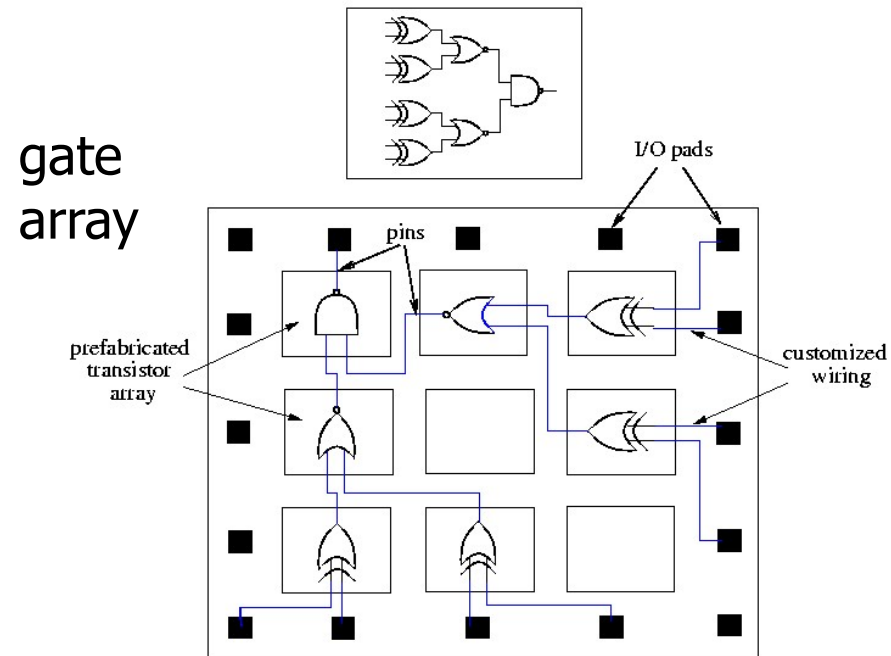

Relation with Routing

- Ideally, placement and routing should be performed simultaneously as they depend on each other's results. This is, however, too complicated.
 - P&R: placement and routing
- In practice placement is done prior to routing. The placement algorithm estimates the wire length of a net using some *metric*.

Estimation of Wirelength

- **Semi-perimeter method:** Half the perimeter of the bounding rectangle that encloses all the pins of the net to be connected. Most widely used approximation!
- **Squared Euclidean distance:** Squares of all pairwise terminal distances in a net using a quadratic cost function

$$\frac{1}{2} \sum_{i=1}^n \sum_{j=1}^n \gamma_{ij} [(x_i - x_j)^2 + (y_i - y_j)^2]$$

- **Steiner-tree approximation:** Computationally expensive.
- **Minimum spanning tree:** Good approximation to Steiner trees.
- **Complete graph:** Since #edges in a complete graph is $\left(\frac{n(n-1)}{2}\right) = \frac{n}{2} \times \# \text{ of tree edges } (n-1)$, $wirelength \approx \frac{2}{n} \sum_{(i,j) \in net} dist(i,j)$.

Estimation of Wirelength (cont'd)

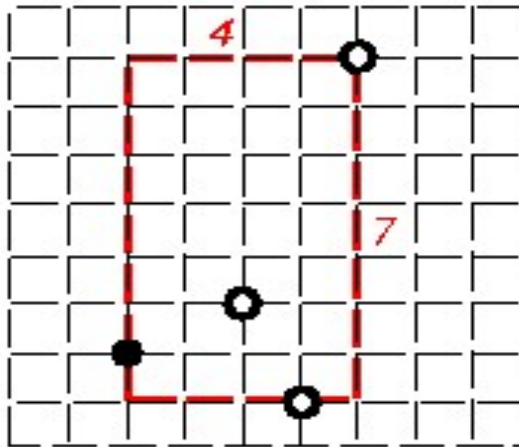

semi-perimeter len = 11

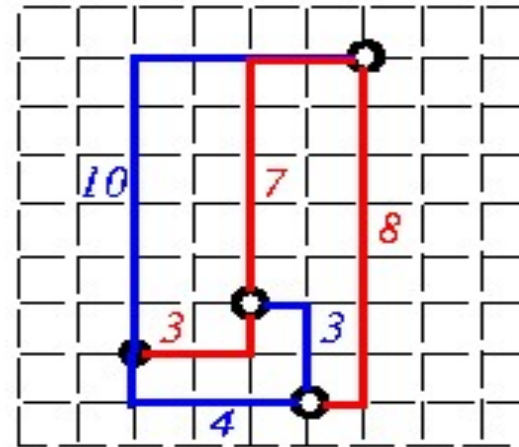

*complete graph len * 2/n = 17.5*

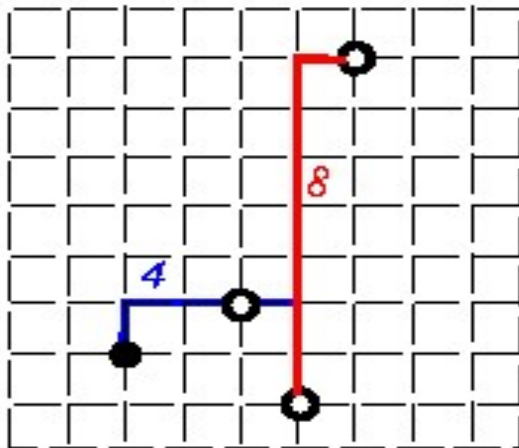

Steiner tree len = 12

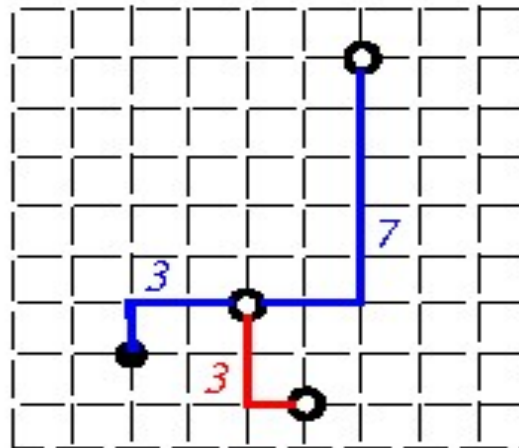

Spanning tree len = 13

Placement Algorithms

- The placement problem is NP-complete
- Popular placement algorithms:
 - **Constructive algorithms:** once the position of a cell is fixed, it is not modified anymore.
 - Cluster growth, min cut, etc.
 - **Iterative algorithms:** intermediate placements are modified in an attempt to improve the cost function.
 - Force-directed method, etc
 - **Nondeterministic approaches:** simulated annealing, genetic algorithm, etc.
- Most approaches combine multiple elements:
 - Constructive algorithms are used to obtain an **initial placement**.
 - The initial placement is followed by an **iterative improvement** phase.
 - The results can further be improved by **simulated annealing**.

Bottom-Up Placement: Clustering

- Starts with a single cell and finds more cells that share nets with it.

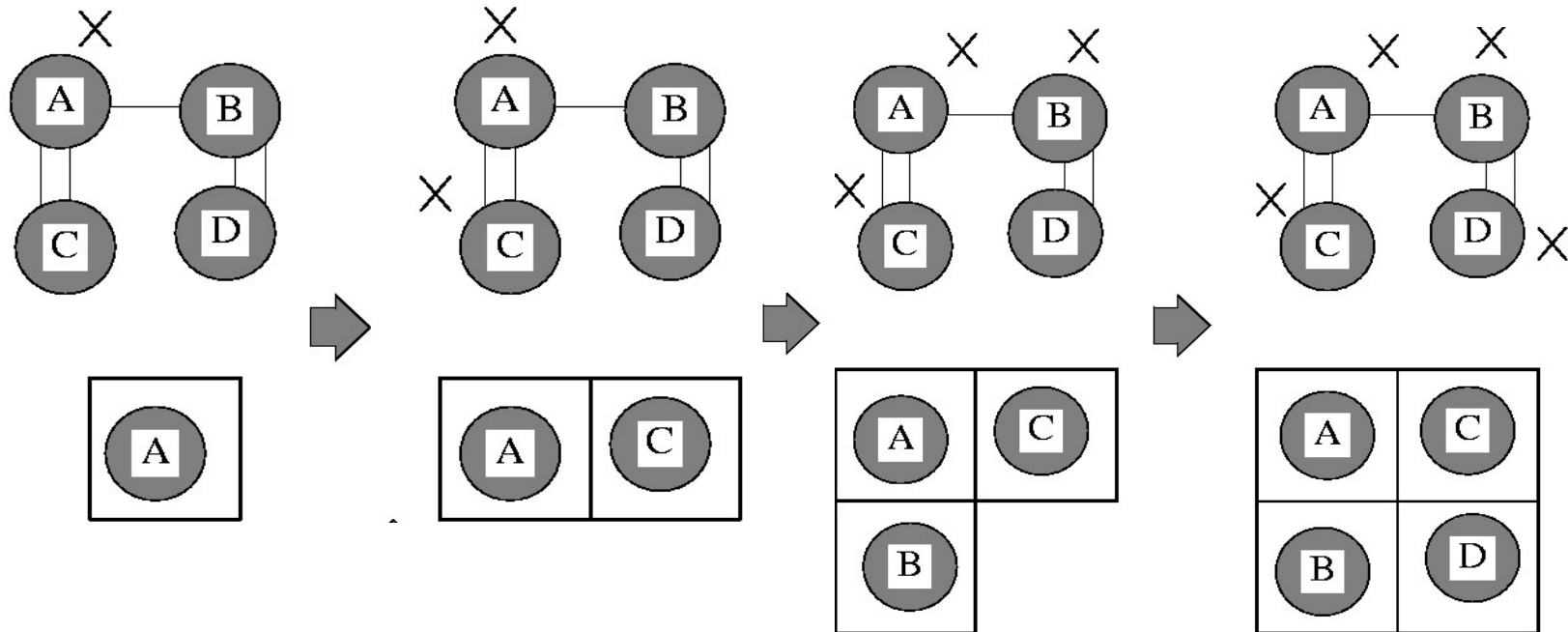

Placement by Cluster Growth

- Greedy method: Selects unplaced components and places them in available slots.
 - SELECT: Choose the unplaced component that is most strongly connected to all of the placed components (or most strongly connected to any single placed component).
 - PLACE: Place the selected component at a slot such that a certain “cost” of the partial placement is minimized.

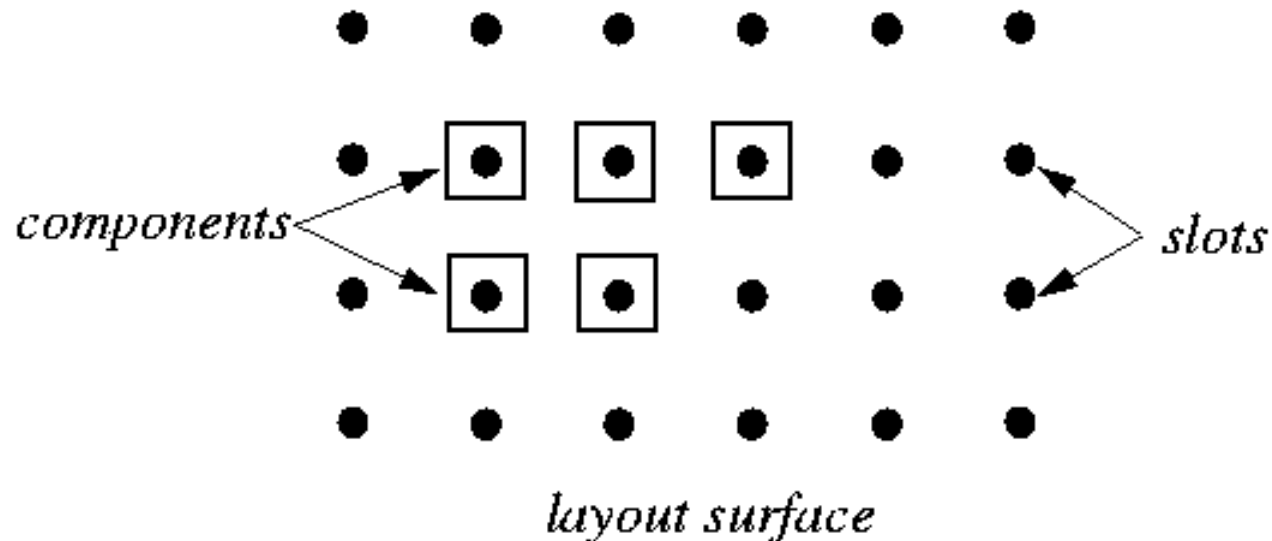

Cluster Growth Example

- # of other terminals connected: $c_a=3$, $c_b=1$, $c_c=1$, $c_d=1$, $c_e=4$, $c_f=3$, and $c_g=3 \Rightarrow e$ has the most connectivity.
- Place e in the center, slot 4. a , b , g are connected to e , and $\hat{c}_{ae} = 2$, $\hat{c}_{be} = \hat{c}_{eg} = 1 \Rightarrow$ Place a next to e (say, slot 3). Continue until all cells are placed.
- Further improve the placement by swapping the gates.

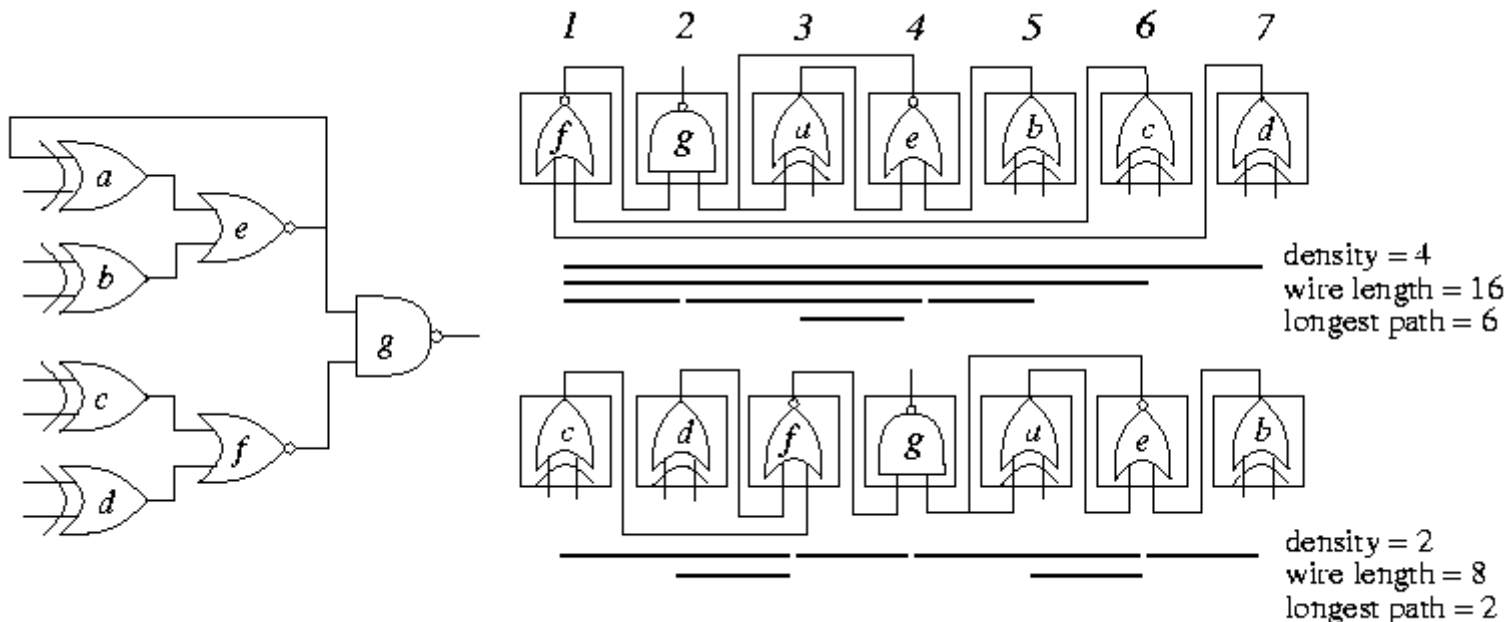

Top-down Placement: Min Cut

- Starts with the whole circuit and ends with small circuits.
- Recursive bipartitioning of a circuit (e.g., K&L) leads to a min-cut placement.

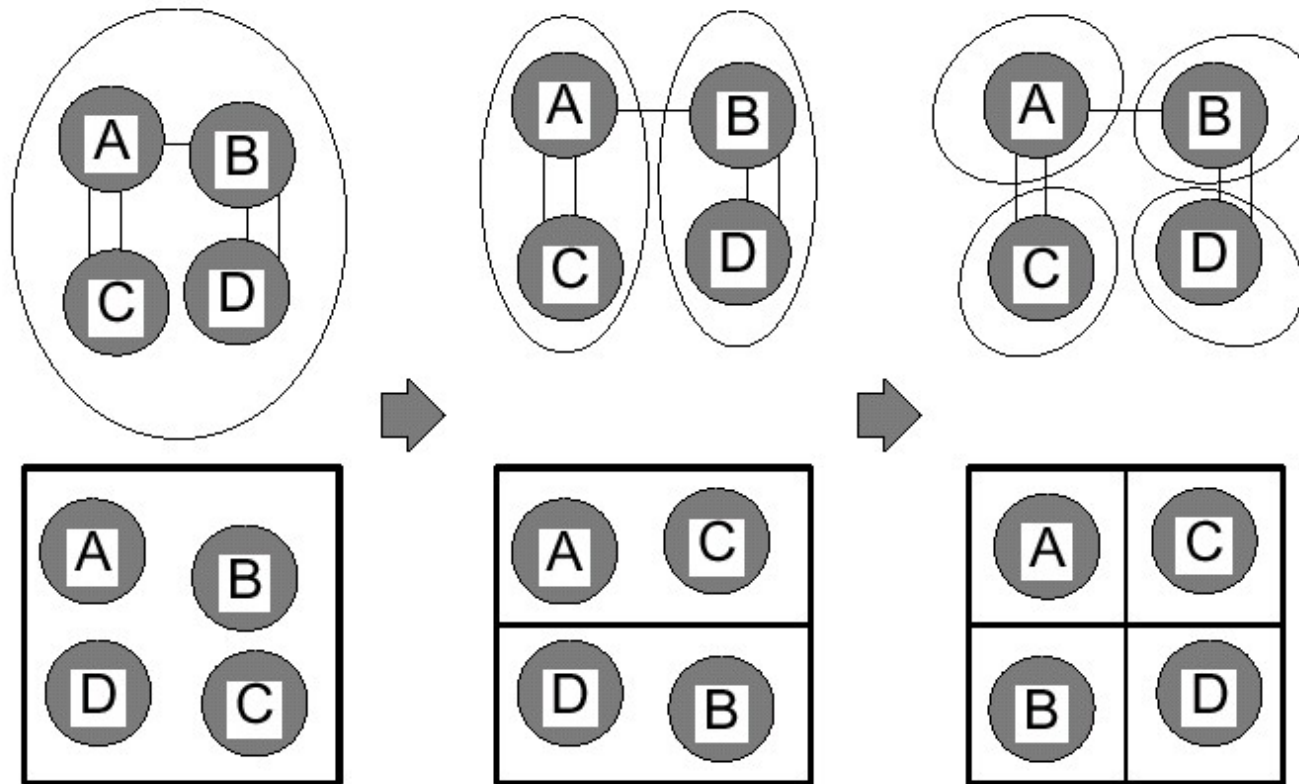

Min-Cut Placement

- Breuer, “A class of min-cut placement algorithms,” DAC-77.
- **Quadrature:** suitable for circuits with high density in the center.
- **Bisection:** good for standard-cell placement.
- **Slice/Bisection:** good for cells with high interconnection on the periphery.

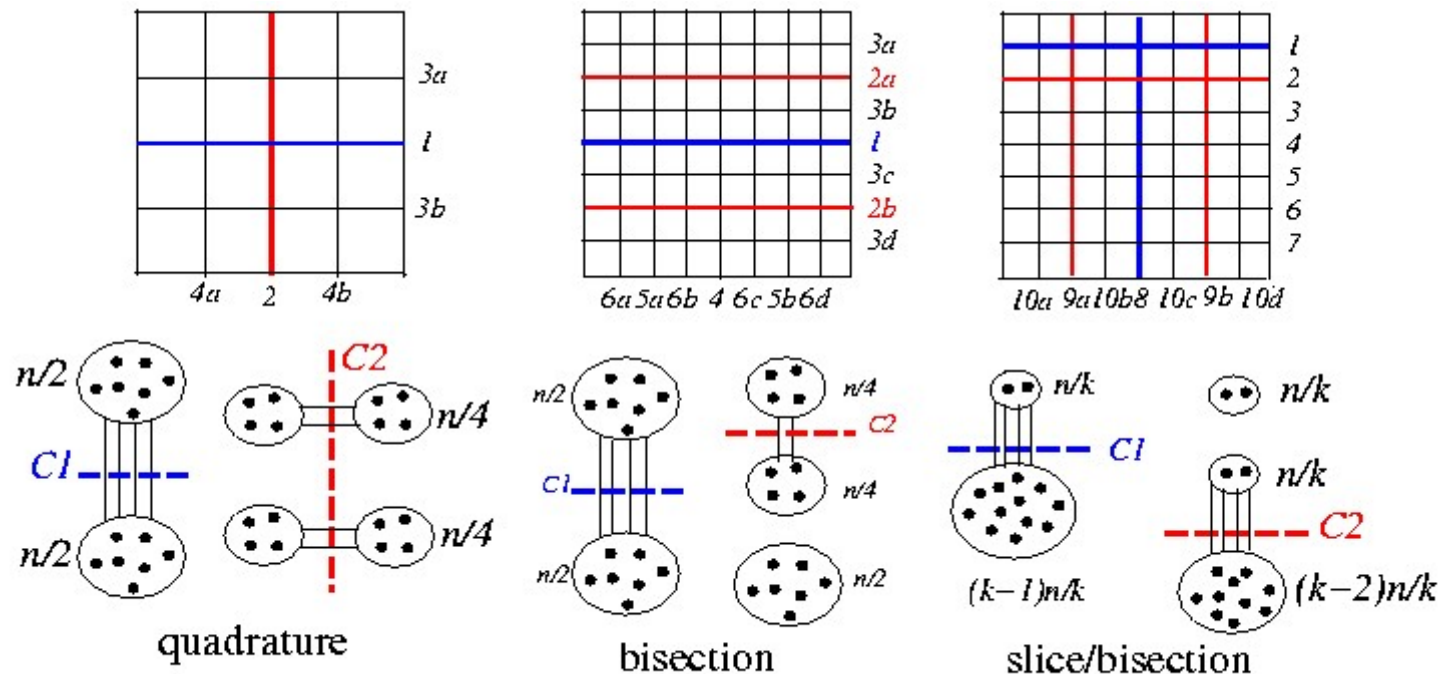

Algorithm for Min-Cut Placement

Algorithm: Min_Cut_Placement(N, n, C)

/ N : the layout surface */*

/ n : # of cells to be placed */*

/ n_0 : # of cells in a slot */*

/ C : the connectivity matrix */*

1 begin

2 if ($n \leq n_0$) **then** PlaceCells(N, n, C)

3 else

4 (N_1, N_2) \leftarrow CutSurface(N);

5 (n_1, C_1), (n_2, C_2) \leftarrow Partition(n, C);

6 Call Min_Cut_Placement(N_1, n_1, C_1);

7 Call Min_Cut_Placement(N_2, n_2, C_2);

8 end

Quadrature Placement Example

- Apply the K-L heuristic to partition + Quadrature Placement: Cost $C_1 = 4$, $C_{2L} = C_{2R} = 2$, etc.

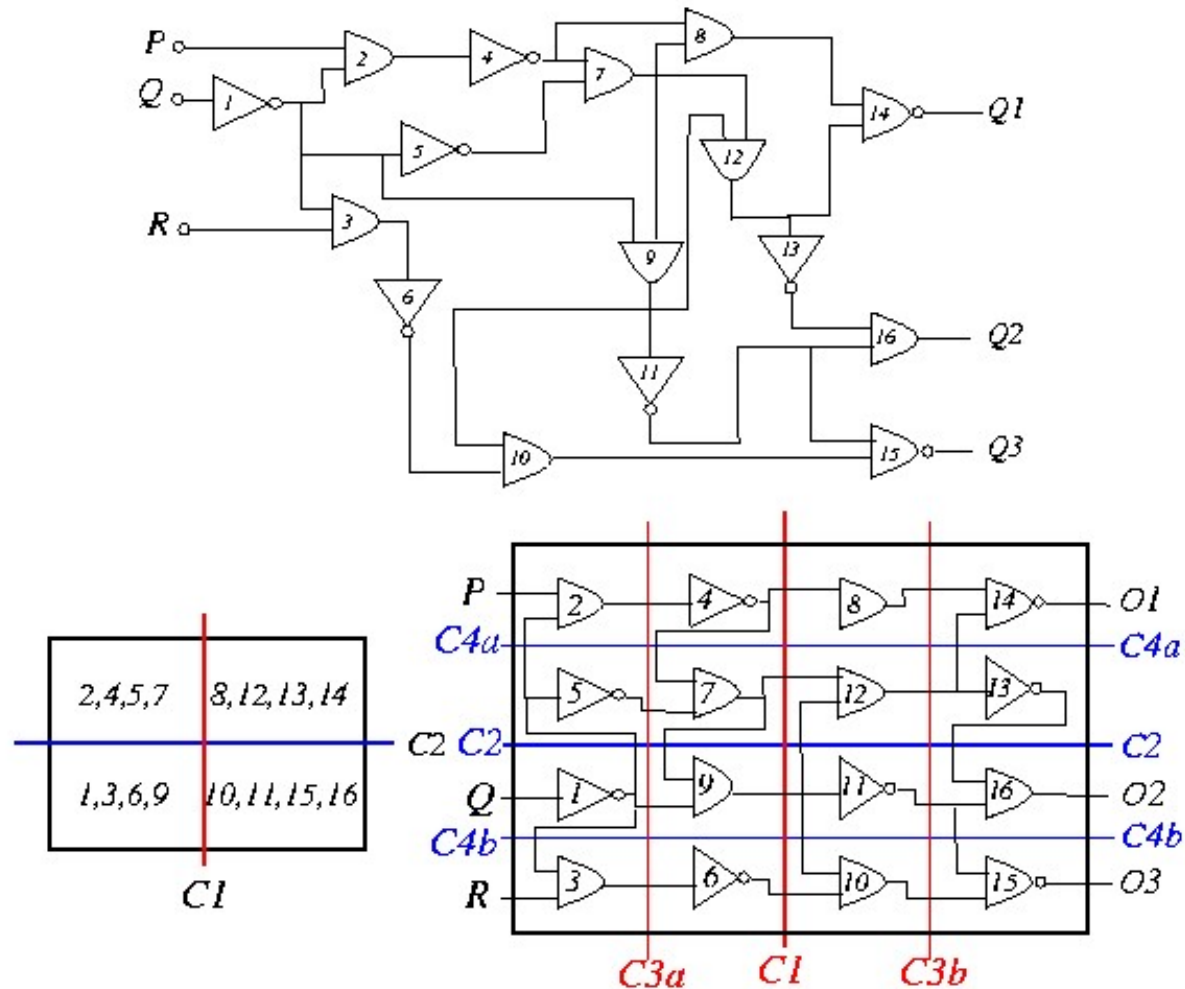

Min-Cut Placement with Terminal Propagation

- Dunlop & Kernighan, “A procedure for placement of standard-cell VLSI circuits,” *IEEE TCAD*, Jan. 1985.
- Drawback of the original min-cut placement: Does not consider the positions of terminal pins that enter a region.
 - What happens if we swap {1, 3, 6, 9} and {2, 4, 5, 7} in the previous example?

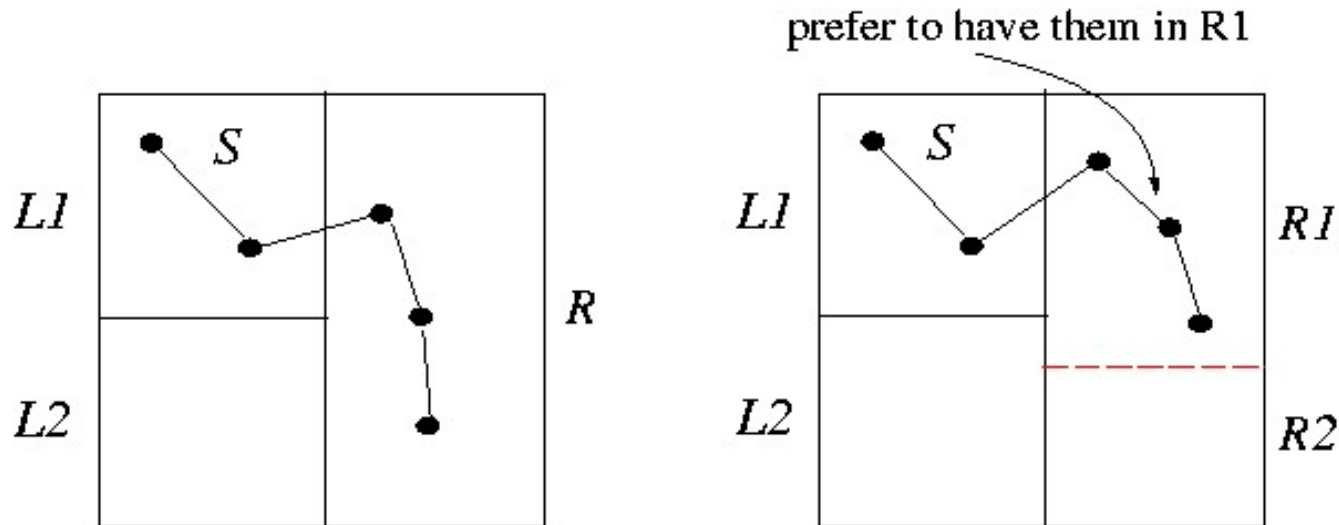

Terminal Propagation

- We should use the fact that s is in L_1 !

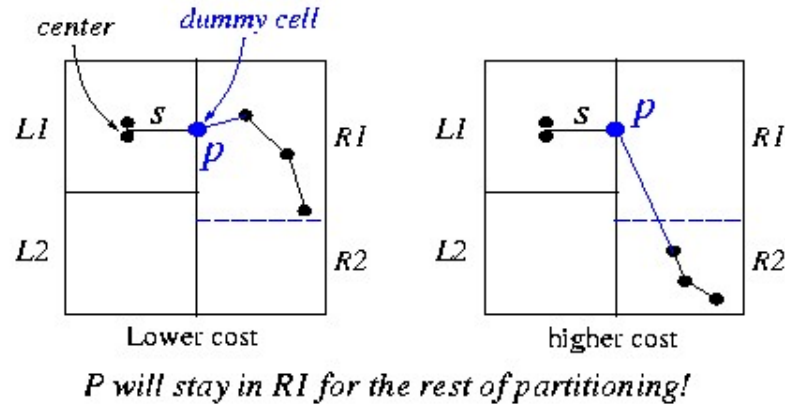

Elements both inside and outside (p_1 - p_3) of G ; p_2 will be ignored due to 1/3 rule

- When not to use p to bias partitioning? Net s has cells in many groups?

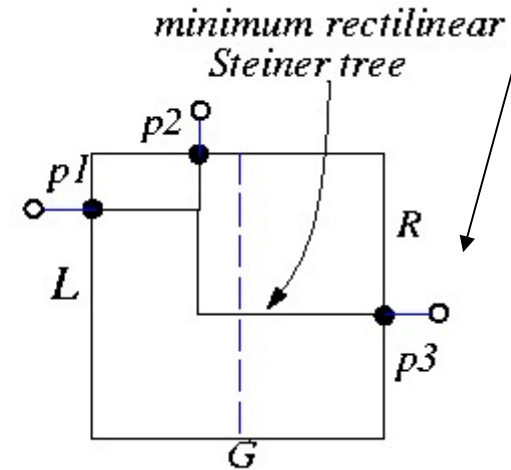
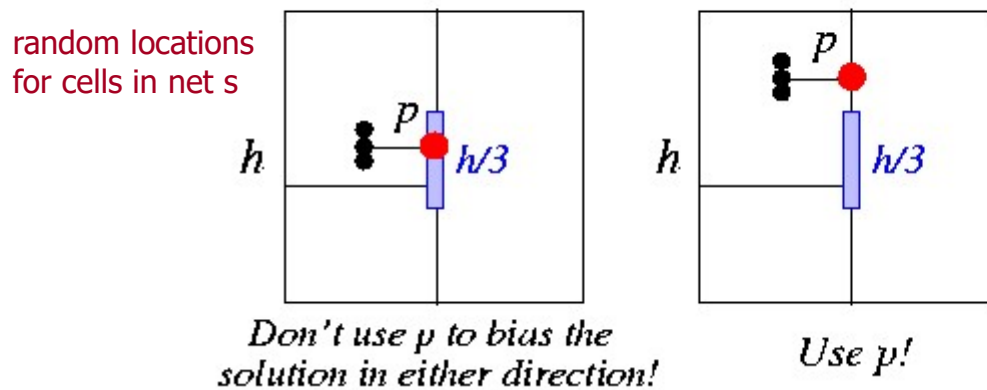

Terminal Propagation Example

- Partitioning must be done breadth-first, not depth-first.

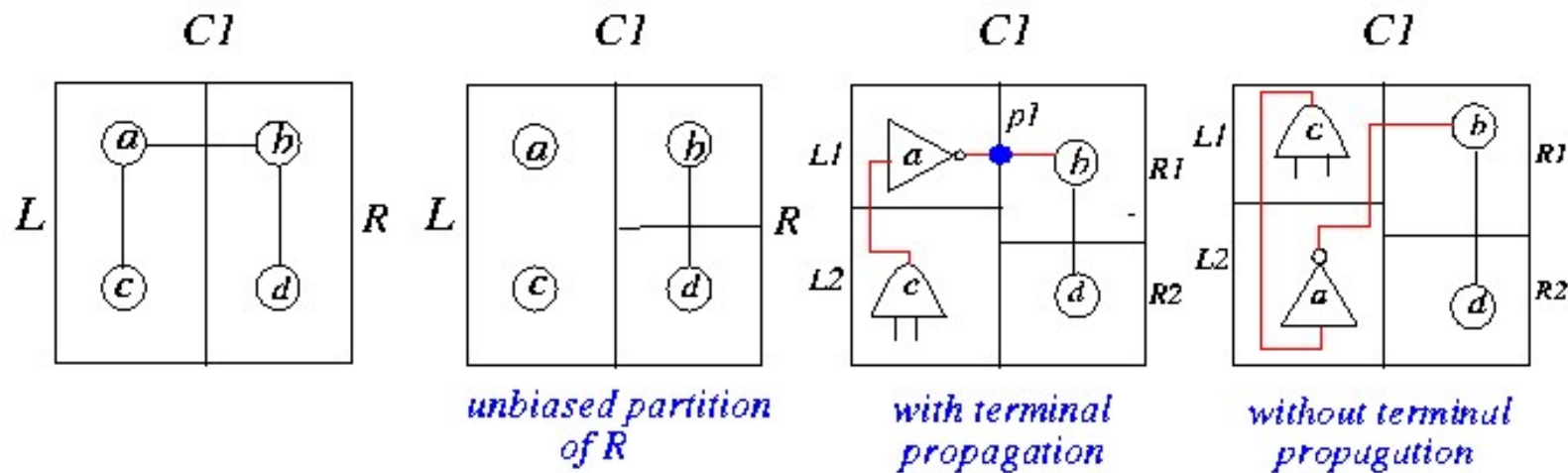
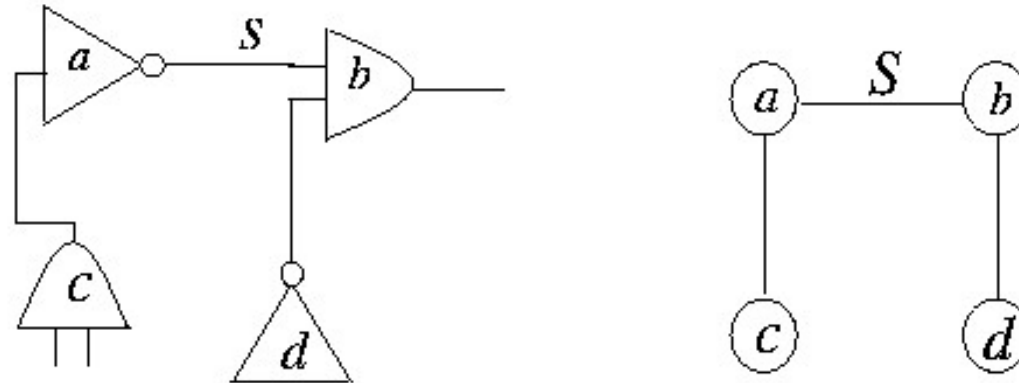

Placement by the Force-Directed Method

- Quinn, Jr. & Breuer, "A force directed component placement procedure for printed circuit boards," *IEEE Trans. Circuits and Systems*, June 1979.
- Reduce the placement problem to solving a set of simultaneous **linear equations** to determine equilibrium locations for cells.
- Analogy to Hooke's law: $F = kd$, F : force, k : spring constant, d : distance.
- Goal: Map cells to the layout surface.

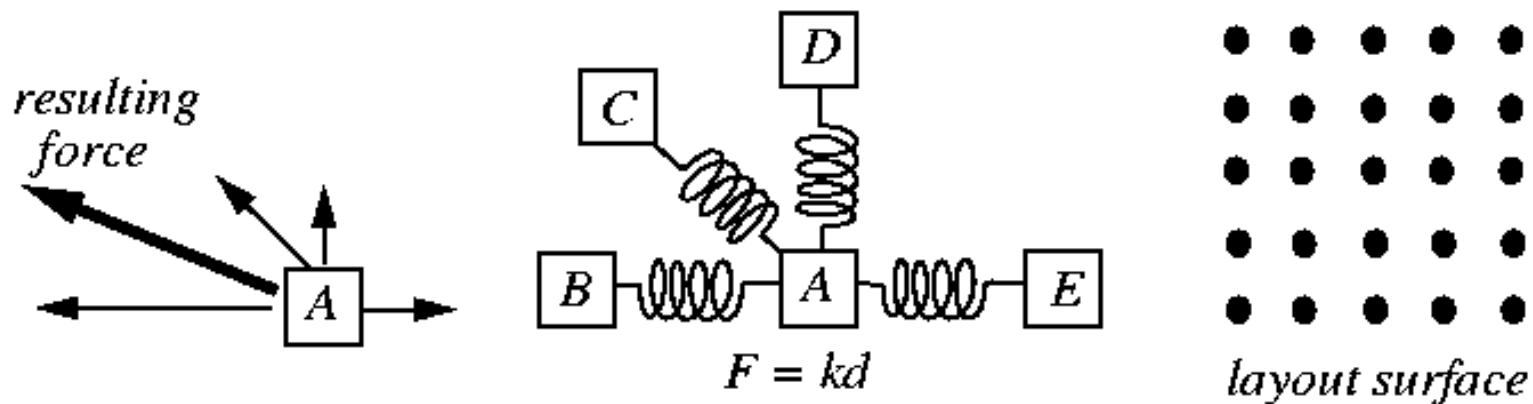

Finding the Zero-Force Target Location

- Cell i connects to several cells j 's at distances d_{ij} 's by wires of weights w_{ij} 's. Total force: $F_i = \sum_j w_{ij} d_{ij}$
- The zero-force target location (\hat{x}_i, \hat{y}_i) can be determined by equating the x- and y-components of the forces to zero:

$$\sum_j w_{ij} \cdot (x_j - \hat{x}_i) = 0 \Rightarrow \hat{x}_i = \frac{\sum_j w_{ij} x_j}{\sum_j w_{ij}}$$

$$\sum_j w_{ij} \cdot (y_j - \hat{y}_i) = 0 \Rightarrow \hat{y}_i = \frac{\sum_j w_{ij} y_j}{\sum_j w_{ij}}$$

- In the example, $\hat{x}_i = \frac{8 \times 0 + 10 \times 2 + 3 \times 0 + 3 \times 2}{8 + 10 + 3 + 3} = 1.083$ and $\hat{y}_i = 1.50$.

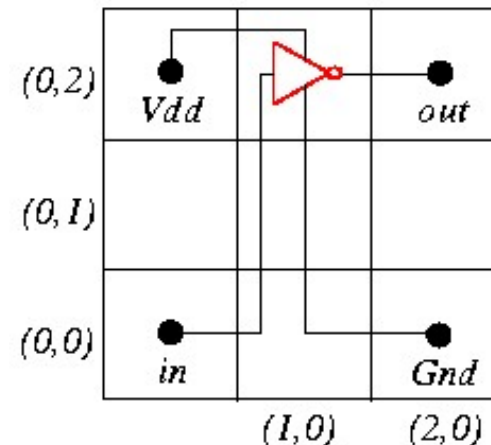
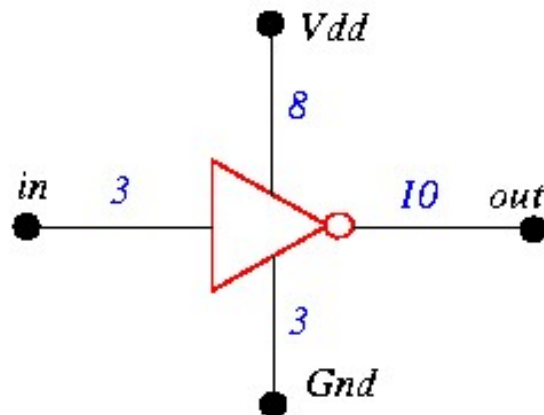

Force-Directed Placement

- Can be constructive or iterative:
 - Start with an initial placement.
 - Select a “most profitable” cell p (e.g., maximum F , critical cells) and place it in its zero-force location.
 - “Fix” placement if the zero-force location has been occupied by another cell q .
- Popular options to fix:
 - **Ripple move:** place p in the occupied location, compute a new zero-force location for q , ...
 - **Chain move:** place p in the occupied location, move q to an adjacent location, ...
 - Move p to a free location close to q .

Example: Kraftwerk

- Hans Eisenmann and F. Johannes, “Generic Global Placement and Floorplanning”, DAC-98, p.269–274.
- Example: layout of a multiplier

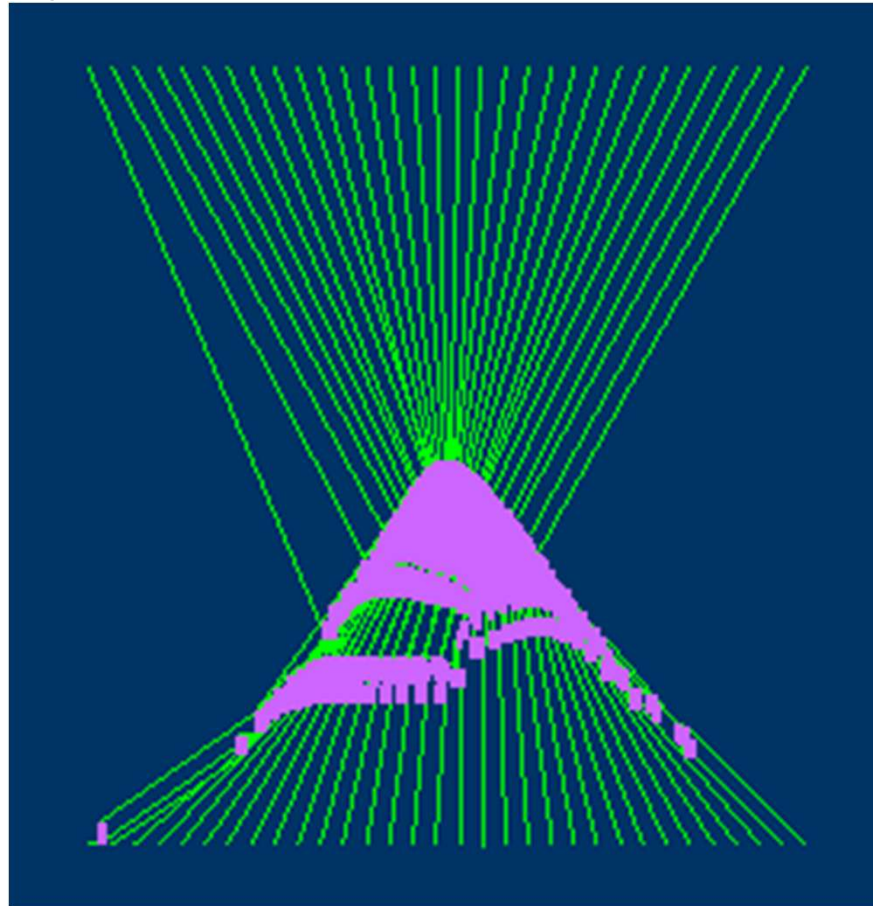

Algorithm: Force-Directed_Placement

```
1 begin
2 Compute the connectivity for each cell;
3 Sort the cells in decreasing order of their connectivities into list L;
4 while (IterationCount < IterationLimit) do
5   Seed ← next module from L;
6   Declare the position of the seed vacant;
7   while (EndRipple = FALSE) do
8     Compute target location of the seed;
9     case the target location
10    VACANT:
11      Move seed to the target location and lock;
12      EndRipple ← TRUE; AbortCount ← 0;
13    SAME AS PRESENT LOCATION:
14      EndRipple ← TRUE; AbortCount ← 0;
15    LOCKED:
16      Move selected cell to the nearest vacant location;
17      EndRipple ← TRUE; AbortCount ← AbortCount + 1;
18      if (AbortCount > AbortLimit) then
19        Unlock all cell locations;
19        IterationCount ← IterationCount + 1;
20    OCCUPIED AND NOT LOCKED:
21      Select cell as the target location for next move;
22      Move seed cell to target location and lock the target location;
23      EndRipple ← FALSE; AbortCount ← 0;
26 end
```

Placement by Simulated Annealing

- Sechen and Sangiovanni-Vincentelli, “The TimberWolf placement and routing package,” *IEEE J. Solid-State Circuits*, Feb. 1985.
- TimberWolf: Stage 1
 - Modules are moved between different rows as well as within the same row.
 - Modules overlaps are allowed.
 - When the temperature is reached below a certain value, stage 2 begins.
- TimberWolf: Stage 2
 - Remove overlaps.
 - Annealing process continues, but only interchanges adjacent modules within the same row.

Solution Space & Neighborhood Structure

- **Solution Space:** All possible arrangements of the modules into rows, possibly with overlaps.
- **Neighborhood Structure:** 3 types of moves
 - M_1 : Displace a module to a new location.
 - M_2 : Interchange two modules.
 - M_3 : Change the orientation of a module.

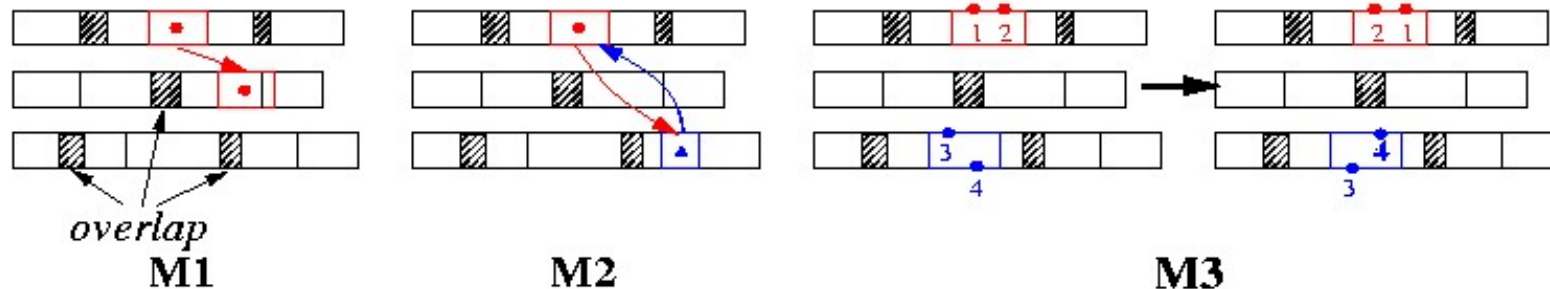

Neighborhood Structure

- TimberWolf first tries to select a move between M_1 and M_2 : $Prob(M_1) = 0.8$, $Prob(M_2) = 0.2$.
- If a move of type M_1 is chosen and it is rejected, then a move of type M_3 for the same module will be chosen with probability 0.1.
- Restrictions: (1) what row for a module can be displaced? (2) what pairs of modules can be interchanged?
- **Key: Range Limiter**
 - At the beginning, (W_T, H_T) is big enough to contain the whole chip.
 - Window size shrinks as temperature decreases. Height & width $\propto \log(T)$.
 - Stage 2 begins when window size is so small that no inter-row module interchanges are possible.

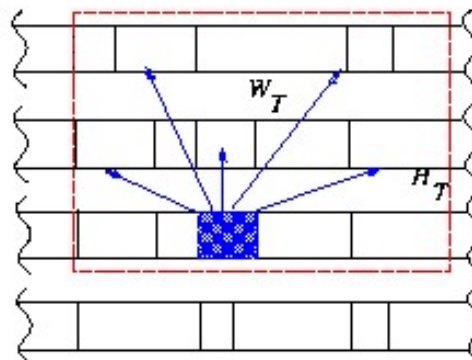

Cost Function

- Cost function: $C = C_1 + C_2 + C_3$.
- C_1 : total estimated wirelength.
 - $C_1 = \sum_{i \in Nets} (\alpha_i w_i + \beta_i h_i)$
 - α_i, β_i are horizontal and vertical weights, respectively. ($\alpha_i=1, \beta_i=1 \Rightarrow$ half perimeter of the bounding box of Net i .)
 - Critical nets: Increase both α_i and β_i .
 - If vertical wirings are “cheaper” than horizontal wirings, use smaller vertical weights: $\beta_i < \alpha_i$.
- C_2 : penalty function for module overlaps.
 - $C_2 = \gamma \sum_{i \neq j} O_{ij}^2$, γ : penalty weight.
 - O_{ij} : amount of overlaps in the x-dimension between modules i and j .
- C_3 : penalty function that controls the row length.
 - $C_3 = \delta \sum_{r \in Rows} |L_r - D_r|$, δ : penalty weight.
 - D_r : desired row length.
 - L_r : sum of the widths of the modules in row r .

Annealing Schedule

- $T_k = r_k T_{k-1}$, $k = 1, 2, 3, \dots$
- r_k increases from 0.8 to max value 0.94 and then decreases to 0.8.
- At each temperature, a total # of nP attempts is made.
- n : # of modules; P : user specified constant.
- Termination: $T < 0.1$.

Placement by the Genetic Algorithm

- Cohoon & Paris, “Genetic placement,” ICCAD-86.
- **Genetic algorithm:** A search technique that emulates the biological evolution process to find the optimum.
- Generic approaches:
 - Start with an initial set of random configurations (**population**); each individual is a string of symbol (symbol string \leftrightarrow **chromosome**: a solution to the optimization problem, symbol \leftrightarrow **gene**).
 - During each iteration (**generation**), the individuals are evaluated using a **fitness** measurement.
 - Two fitter individuals (**parents**) at a time are selected to generate new solutions (**offsprings**).
 - Genetic operators: **crossover, mutation, inversion**
- In the example, string = [aghc**b**idef]; fitness value = $1/\sum_{(i,j) \in E} w_{ij} d_{ij} = 1/85$.

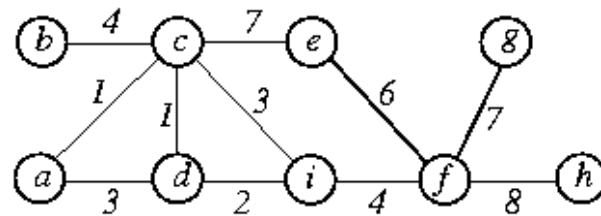

6	7	8
3	4	5
0	1	2

d	e	f
c	b	i
a	g	h

string: aghc**b**idef

Genetic Operator: Crossover

- Main genetic operator: Operate on two individuals and generates an offspring.

- $[bidef|aghc](\frac{1}{86}) + [bdefi|gcha](\frac{1}{110}) \rightarrow [bidefgcha](\frac{1}{63})$.

- Need to avoid repeated symbols in the solution string!

- **Partially mapped crossover** for avoiding repeated symbols:

- $[bidef|gcha](\frac{1}{86}) + [aghcb|idef](\frac{1}{85}) \rightarrow [bgcha|idef]$.

- Copy *idef* to the offspring; scan $[bidef|gcha]$ from the left, and then copy all unrepeated genes.

Two More Crossover Operations

- Cut-and-paste + Chain moves:
 - Copy a randomly selected cell e and its four neighbors from parent 1 to parent 2.
 - The cells that earlier occupied the neighboring locations in parent 2 are shifted outwards.
- Cut-and-paste + Swapping
 - Copy $k \times k$ square modules from parent 1 to parent 2 (k : random # from a normal distribution with mean 3 and variance 1).
 - Swap cells X,P,W,M,N (in parent 2) to the slots of cells A,C,D,E,F original positions

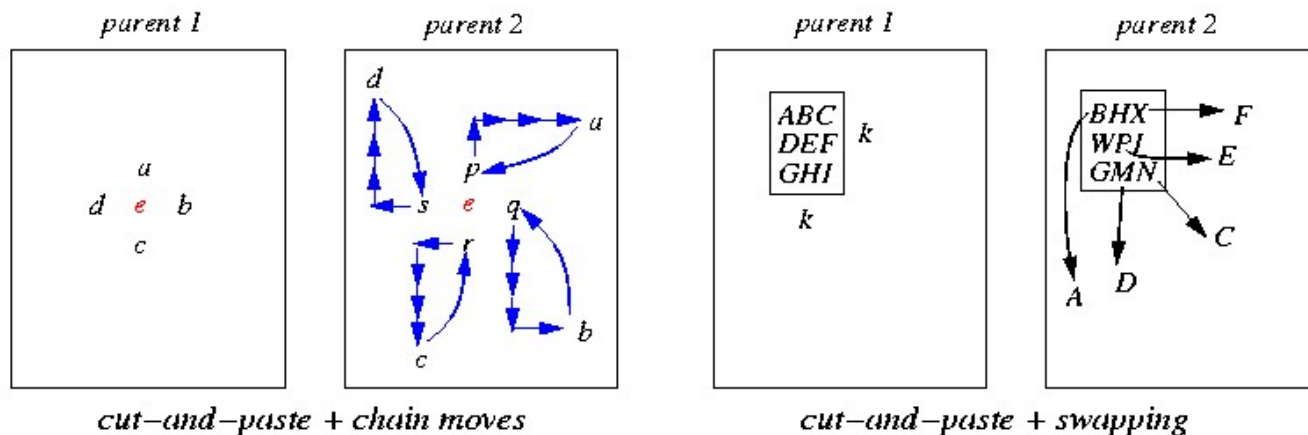

Genetic Operators: Mutation & Inversion

- **Mutation:** prevents loss of diversity by introducing new solutions.
 - Incremental random changes in the offspring generated by the crossover.
 - A commonly used mutation: pairwise interchange.
- **Inversion:** $[bid|efgch|a] \rightarrow [bid|hcgfe|a]$.
- Apply mutation and inversion with probability P_μ and P_i respectively.

Algorithm: Genetic_Placement($N_p, N_g, N_o, P_i, P_\mu$)

/ N_p : population size; */*

/ N_g : # of generation; */*

/ N_o : \# of offspring; */*

/ P_i : inversion probability; */*

/ P_μ : mutation probability; */*

1 begin

2 ConstructPopulation(N_g); */* randomly generate the initial population */*

3 for $j \leftarrow 1$ **to** N_p

4 Evaluate Fitness(*population*(N_p));

5 for $i \leftarrow 1$ **to** N_g

6 for $j \leftarrow 1$ **to** N_o

7 (x, y) \leftarrow ChooseParents; */* choose parents with probability \propto fitness value */*

8 *offspring*(j) \leftarrow GenerateOffspring(x, y); */* perform crossover to generate offspring */*

9 for $h \leftarrow 1$ **to** N_p

10 With probability P_μ , apply Mutation(*population*(h));

11 for $h \leftarrow 1$ **to** N_p

12 With probability P_i , apply Inversion(*population*(h));

13 Evaluate Fitness(*offspring*(j));

14 *population* \leftarrow Select(*population*, *offspring*, N_p);

15 return the highest scoring configuration in *population*;

16 end

Genetic Placement Experiment: GINIE

- Termination condition: no improvement in the best solution for 10,000 generations.
- Population size: 50. (Each generation: 50 unchanged throughout the process.)
- Each generation creates 12 offsprings.
- Comparisons with simulated annealing:
 - Similar quality of solutions and running time.
 - Needs more memory.

Modern Placement Challenges

- High complexity
 - Millions of objects to be placed
- Placement constraints
 - Preplaced blocks
 - Chip density
 - Many others
- **Mixed-size placement**
 - Hundreds/Thousands of large macros with millions of small standard cells

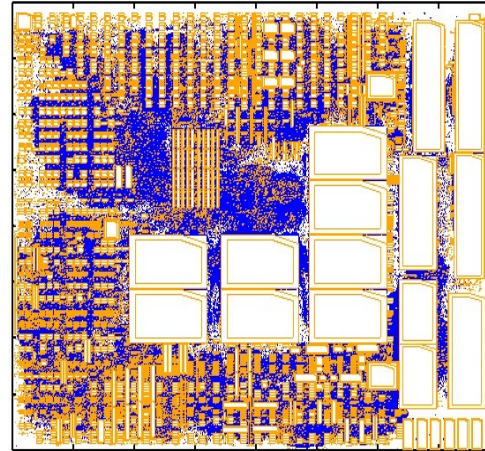

2.5M
placeable
objects
mixed-size
design

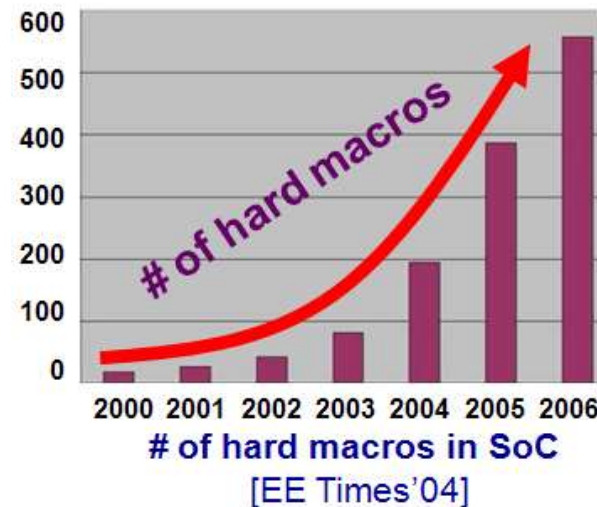

Macros have
revolutionized
SoC design

Modern Placement Steps

- Chen, et al., “A high quality analytical placer considering preplaced blocks and density constraint,” ICCAD-06 (TCAD-08)

